

FEATURE

- . 완전 밀폐구조의 압축 & 인장 로드셀
- . 우수한 내피 특성
- . 축하중에 강한 구조
- . 방진, 방수등급 : IP67

SPECIFICATION

MODEL	CLS
Rated capacity (R.C.)	1, 2, 3, 5, 10, 20, 50, 100, 200 tf
Rated output (R.O.)	2.0 ± 0.005 mV/V
Zero balance	0 ± 0.02 mV/V
Combined error	0.05% R.O.
Repeatability	0.02% R.O.
Creep for 30 min	0.05% R.O.
Temp. effect on zero value	0.03% / 10°C
Temp. effect on output value	0.03% / 10°C
Excitation recommended	10V DC
Excitation maximum	15V DC
Terminal resistance, input	350 ± 3.5Ω
Terminal resistance, output	350 ± 3.5Ω
Insulation resistance	> 2000MΩ @ 50V DC
Compensated temperature range	-10 to +40°C
Operating temperature range	-20 to +80°C



- Material	Paint finished steel
- Cable	Braided Shield 4-wire round cable with PVC-jacket

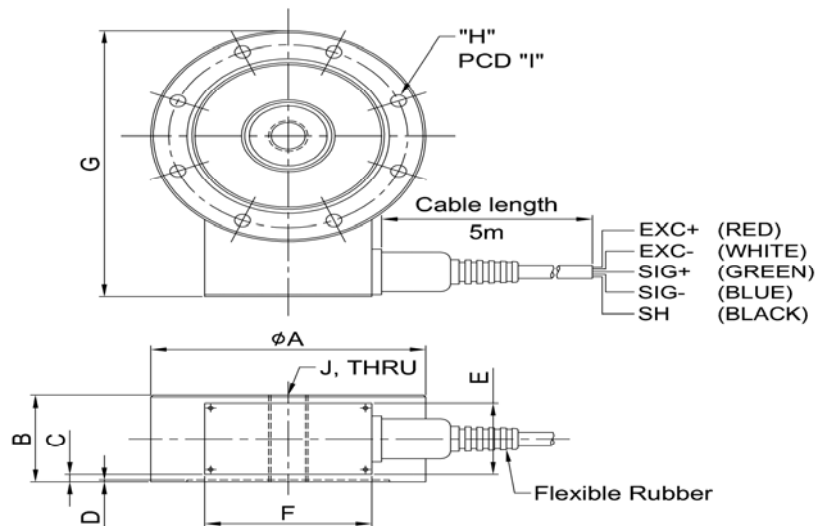

DIMENSION (mm)

Rated Capacity	φA	B	C	D	E	F	G	H	I	J
1, 2, 3tf	110	46	4	1	38	68	139.5	8-φ6.6	97.2	M16 x 2.0
5tf	120	46	4	1	38	68	149.5	8-φ9	103.2	M18 x 1.5
10tf	138	60	11	1	38	68	167.5	8-φ11	117.6	M24 x 2.0
20tf	184	80	21	1	38	68	213.5	8-φ14	157.6	M39 x 2.0
50tf	200	60	11	1	38	68	229.5	12-φ14.3	170	M45 x 3.0
100tf	278	90	26	1	38	68	307.5	16-φ16.3	229	M70 x 3.0
200tf	355	108	35	1	38	68	384.5	12-φ26	298	M90 x 3.0