

FEATURE

- . Mounting 일체형 시어빔형 로드셀
- . 탱크, 호퍼의 플랫폼 스케일에 최적
- . 방진, 방수 등급 : IP66

SPECIFICATION

MODEL	CBSB
Rated capacity (R.C.)	150, 250, 300, 500 kgf 1, 2, 3, 5, 10 tf
Rated output (R.O.)	3.0 ± 0.0075 mV/V 150kgf:1.5mV/V, 300kgf: 2.0mV/V
Zero balance	0 ± 0.03 mV/V
Combined error	0.03% R.O.
Repeatability	0.01% R.O.
Creep for 30 min	0.03% R.O.
Temp. effect on zero value	0.028% / 10°C
Temp. effect on output value	0.015% / 10°C
Excitation recommended	10V DC
Excitation maximum	15V DC
Terminal resistance, input	350 ± 3.5Ω
Terminal resistance, output	350 ± 3.5Ω
Insulation resistance	> 2000MΩ @ 50V DC
Compensated temperature range	-10 to +40°C
Operating temperature range	-30 to +80°C



- Mounting		
Capacity	Hexagon head-Bolt	Tightening torque
150kgf ~2tf	M12 x 1.75(10.9)	100Nm
3tf ~ 5tf	M18 x 1.5(10.9)	350Nm
10tf	M24 x 2.0(10.9)	860Nm

- Material	
Nickel plated steel	

- Cable	
Braided Shield 4-wire round cable with PVC-jacket	

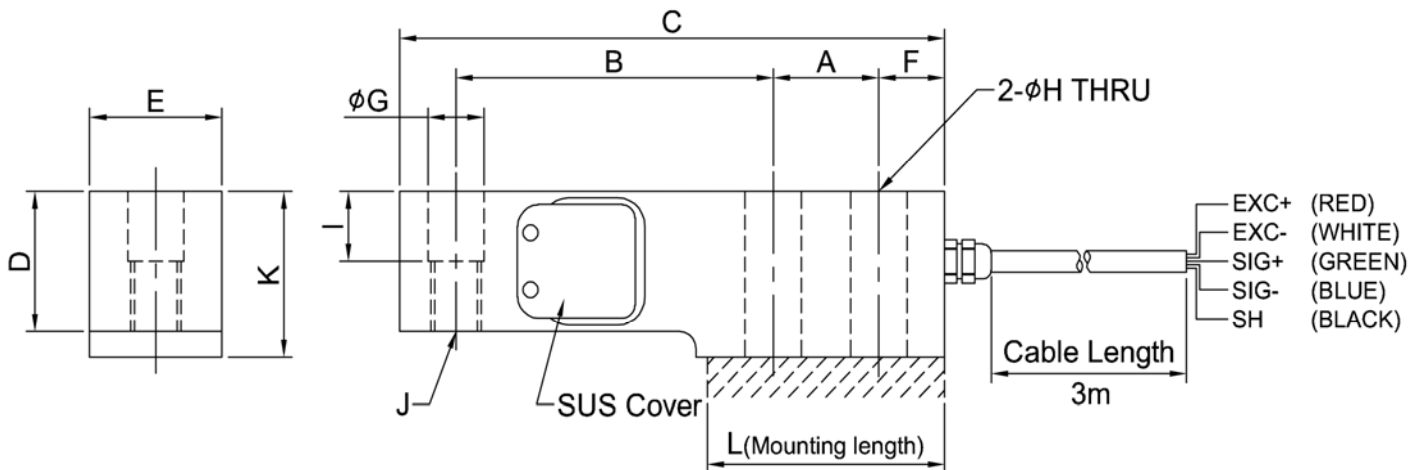

DIMENSION (mm)

Rated Capacity	A	B	C	D	E	F	φG	φH	I	J	K	L
150, 250, 300, 500 kgf 1, 2tf	25.4	76.2	131	32	31.8	15.8	13.5	13.5	16	M12x1.75	38	57
3, 5tf	38.1	95.3	171.5	38	38	19	20	20	19	M18x1.5	44.5	76
10tf	50.8	120.7	222.3	50.8	50.75	25.4	26.2	26.2	25.4	M24x2.0	57.2	108